

# Environmental Control Booth

## Models ECB-2, ECB-3, & ECB-4

A self-contained workstation with high filtration efficiency, built-in lighting, soundproofing, and low maintenance requirements.



ECB-2

### Powerful

- The Ultra-Web® filter cartridge, featuring nanofiber technology, provides high filtration efficiency and long filter life.
- Choice of filter cartridges provides high filtration efficiency for a wide variety of dust types.

### Flexible

- Booth design gives workers complete freedom of movement and improved vision.
- Modular, compact design permits proper sizing for each application.

### Cost Effective

- Removes fine airborne dust from multiple sources.
- Provides a clean working environment for maximum productivity.
- Recirculates clean air, eliminating need for costly make-up air.
- Requires no ductwork, reducing installation costs.
- Excellent dust filtration capabilities reduce mechanical and electrical failures caused by airborne dust.

# Environmental Control Booth

## Dimensions & Specifications

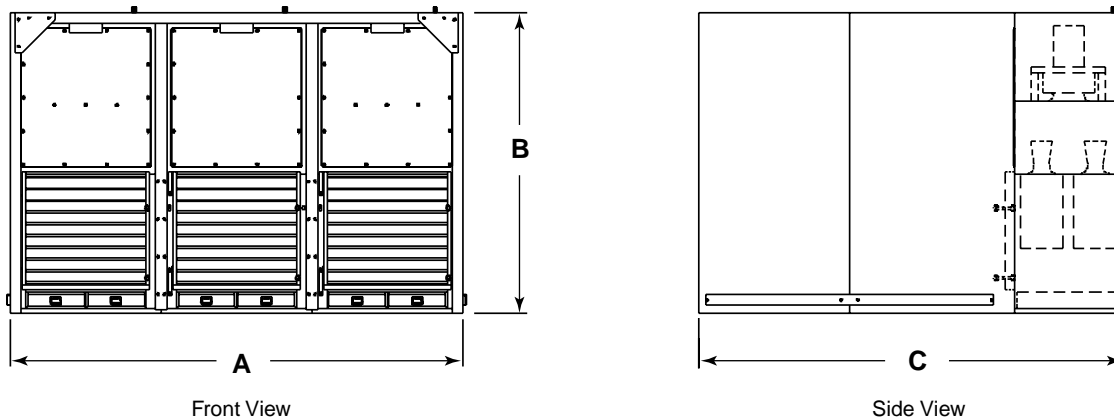

Model	A	B	C
Power Module Only	45.0	90.0	34.5
ECB-2	90.1	90.0	128.9
ECB-3	135.1	90.0	128.9
ECB-4	180.8	90.0	128.9

All dimensions in inches and for reference only

Model	Nominal Airflow* (cfm)		No. of Cartridges	Filter Area Ultra-Web® (ft²)	Average Face Velocity (fpm)		No. of Valves	Shipping Weight (lbs)	Compressed Air Pressure (psig)
	High Flow	Low Flow			High Flow 5 hp Fan	Low Flow 3 hp Fan			
Power Module Only	4,500	3,000	6	1356	-	-	3	750	90
ECB-2 (2 Pwr Mods)	9,000	6,200	12	2712	160	110	6	2700	90
ECB-3 (3 Pwr Mods)	13,500	9,300	18	4068	160	110	9	3900	90
ECB-4 (4 Pwr Mods)	18,000	12,400	24	5424	160	110	12	5100	90

\* Based on clean filters.

## Equipment Options

- Acoustical Booth
- Galvanized Booth
- Fans (low flow)
- Control Panels
- Inlets
- Afterfilters
- Ultra-Web® FR, Fibra-Web® FR, Ultra-Tek® and Torit-Text™ filter cartridges.



Donaldson Company, Inc.  
 Industrial Air Filtration  
 P.O. Box 1299  
 Minneapolis, MN 55440  
 Tel 800-365-1331(USA)  
 Tel 800-343-3639 (Mexico)  
 dustmktg@mail.donaldson.com  
 www.donaldson.com



Information in this document is subject to change without notice.

© 1997 Donaldson Co., Inc.  
 Printed in U.S.A. on recycled paper  
 Data Sheet ECB(03/03)